

829095 - High Pressure Fuel Pump Puller

Description:

As of 2011 Ford changed the method of fuel pump sprocket removal on the 2.2 TDCI (Puma) diesel engines. The sprocket no longer has threaded holes which means the legs of the puller used to remove the sprocket must be hooked in shape.

The K00286 puller allows the removal of these sprockets by allowing the High Pressure diesel injection pump to be pushed out of the pump sprocket to enable pump removal without disturbing the timing chain.

Special Note:

To perform this task the 829095 must be used with Ford special tool 303-1151 (sprocket holding tool).

Note: The 829095 kit contains a force screw. Force screws must be lubricated with high pressure grease. Sonic recommends the use of Molybdenum Disulphide Grease (drive shaft grease).

Do not use assembly or anti-seize greases (copper greases).

Equivalent to OEM 303-249, 303-249-01

Components

Ref	Comp	OEM	Description
1		303-249-01	Hooked Legs
2		303-249-01	Centre piece
3		303-249	Puller Bridge
4		303-249-01	Force Screw
5		303-249	Straight Threaded Legs
6		999 5382	Probe

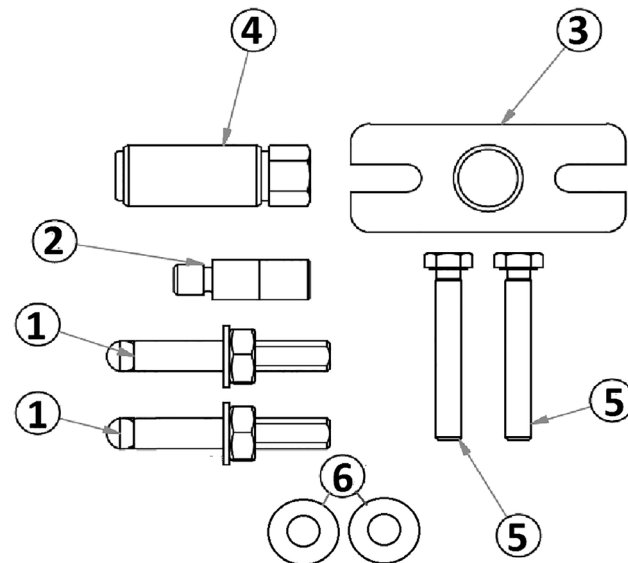

Instructions

The following instructions are for guidance only. Please refer to OEM derived data such as the vehicles manufactures own data or Autodata. The use of these engine timing tools is purely down to the user's discretion and Sonic cannot be held responsible for any damage caused what so ever.

